

Installation instructions for the LWFA:

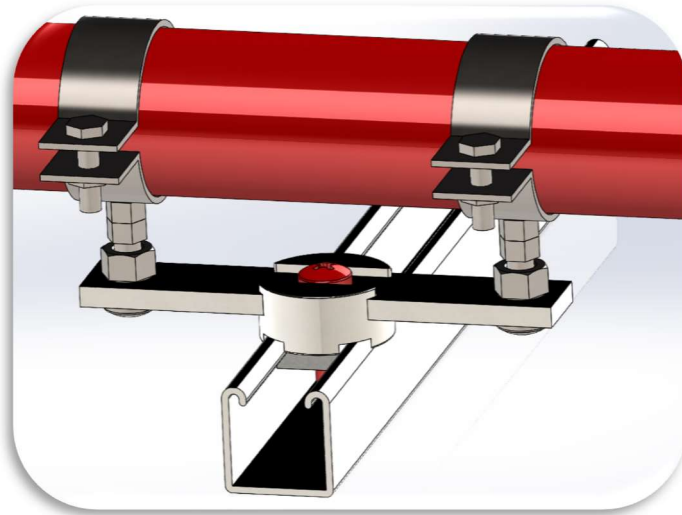

This is an Anchor Point, designed to rigidly fix pipework. The LWFA is perfectly designed to clamp onto 41mm Strut Profiles. Recommended profile is 41x41x2.5mm

1. Ensure the “Strut” you are connecting to is suitably fixed to the building. Ideal connections include
 - a. Minimum 2 concrete screws (+1 addition for each unit); screws should not be more than 250mm from the LWFA
 - b. Hat Brackets when connection to existing frames, (Strut frames should be designed by a suitably qualified Engineer)
 - c. Hanging Rod and suspension methods are **not acceptable**
2. Place the LWFA onto the Strut Rail, Rotate the Locking Bolt (RED) until the Channel nut is correctly located “Image”
3. Apply Torque setting of 40 Nm should be applied
4. Clips are not provided as part of the LWFA range, please secure suitable clips to the M10 rods provided and Torque the Clamps in line with Manufacturers recommendations